

NOTES:

### 6' STANDARD IDLER ROLLER CONVEYOR

#### Specifications:

--**Rollers:** 2-1/2" diameter x 11 ga wall, 16" working width, 12" on center, 700# capacity per roller, 11/16" hex shaft.

--**Frame:** 5" x 6.7# channels.

--**Legs:** 4" x 5.4# channels, Height to be 21" + or - 3" Adjustable Leveling Bolt

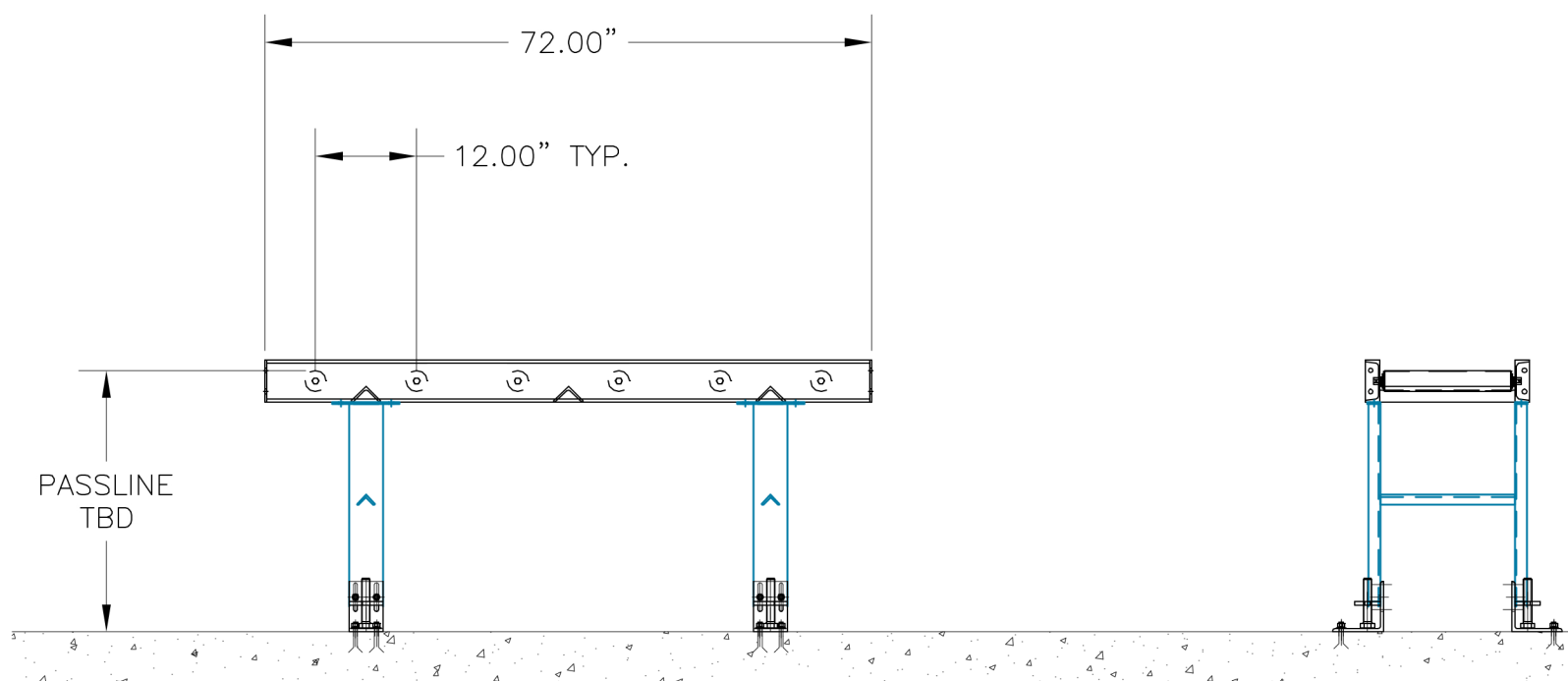
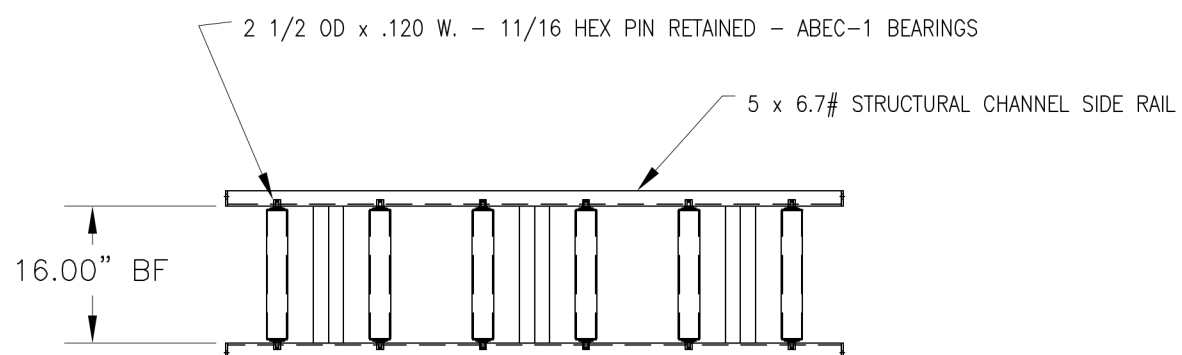

16" WORKING WIDTH CONVEYOR



**Metal Sawing Technology** ©